

# GSM Based Smart Bus Safety System Using RFID



Deepak Aggarwal

Keeping students and drivers safe is a top priority for all schools, colleges and other educational institutions. The safety and security of children is a concern for the management of all the school/colleges as well as for the parents. This is why Global Positioning System (GPS) have become a critical tool for school/ college transportation. The proposed system will control the entry and exit of students to and from the bus using RFID (Radio Frequency Identification) and GSM technologies to ensure the entering and exiting of all students to and from the school bus in a safer manner. The process, does not require any additional action by the student and drivers. The system will do all the process and allow the student to be tracked while entering and leaving the bus. If the bus journey is successful from the source to destination, it will send an SMS to the management to inform its departure and arrival.

School buses transfers millions of children daily in various countries around the world. Schools today are increasingly using GPS enabled school bus tracking system, ensuring student safety during transit. While there many issues that might disturb the parents regarding the travel safety of school going children, the project intends to look into introducing access safety in respect of school buses through bus tracking system that will help the school children's transportation in a secure and safer way. The supervision of the regularity of students during their entry and exit from the bus is difficult to be controlled by drivers, which led to endangering child safety.

The phenomenon of forgetting kids on the bus is one of the problems suffered by the children, which has increased significantly in recent years. This has often led to the death of many students on account of suffocation due to the lack of attention of derivers. This project, through entry and exit recordings, aims to create a suitable environment by following certain set of criteria of security and



safety for school bus that will have a positive impact on the student and their family.

The project proposed a bus safety system which was designed to control the entering/exiting of students from the bus.

This system does several tasks, including identifying personal information (Eg. Name) of each student using RFID tag, which will exchange the data with the RFID reader via radio waves, and displaying each student name into LCD display. This will let the driver to know the number of students inside the bus and the students who departed from the bus. Moreover, the system has an emergency system that will alert in case if there is a child inside the bus after the bus stops at the destination by sending an SMS to the school management via GSM modem. In addition, if the bus depart and arrive successful from the source to destination, it will inform the management through an SMS about its successful departure and arrival. The key novel feature of the proposed methodology is the use of energy efficient systems to support the tasks. Though not within strictly in the scope, the same data can be used to assess the time of departure and arrival, number of students travels each day.

## Study & Reserach

A literature review has showed there are many

studies made use of Radio Frequency identification (RFID) as a system that transmits the identity of an object using radio waves. This identity is transmitted in a form of serial number that distinguishes each object from others. The RFID system consists of an RFID reader and an RFID tag. The tag consists of the microchip that is connected to an antenna; microchip can store a maximum of 2 KB of data, which may include data and information about the product, manufacturing date, and destination.

Further, it is also observed that the ability of the reader field decreases quickly with increasing distance, which defines the area of reading to 4-5 meter distance using VHF 860-930 MHz. Another research introduced a system that monitors children inside the bus in a safe manner. It uses a combination of RFID, GPS (Global Positioning System), and GPRS (General Packet Radio Service) technologies. Each student carries a unique RFID card. The card is embedded in each of the student's school bags. Whenever a student enters or exits from the bus, the reader records the time, date, and location and then transfer the data into a secure database and this does not require any action from the drivers and students.

The system enables parents to receive instant SMS alerts within 10 minutes of the designated pick up and drop off points, reducing the time the child spends on the street. The system will also notify the parents via SMS when the student boards from the bus or when entering and leaving the school, this will make the parents take the appropriate action because they have precise answers to boarding status and times. If the child is still inside the bus for a predetermined period after running the bus engine, and bus's doors are closed, a message will be sent to school management, and the system will display the location of the bus.

In addition, the system includes a web -based reporting that makes it fast and easy access to get accurate information, such as student report that provides a data and time for all the activities of loading and unloading by students, and bus report that provides all student ridership data by bus. Another study carried out applied new technologies in order to upgrade transport services and raise the level of traffic safety during the transfer the school students and as well as, to allow families of the students to trace the route of their children while they are in school buses. This system consists of

three techniques, such as smart card, tracking device and the golden rule. The student scans the card when he/she come up to the bus via a device fixed in the bus and he should do the same thing when he got off from the bus. Based on that parent receives a text message during the student scan of the card when entering and exiting. The tracking device technique also will enable parents to determine the route of the bus to follow its path on a map that can be found via a mobile phone, once the student entered the bus, and scanned the card. On the other hand, the golden rule, which is a golden box drawn on the area of parking buses inside a red box that is bigger than it is to warn students from bypassed. In order to alert them to not cross the road when there is a vehicle and it avoid deadly stampedes or presenting in front of the bus moving, for their own safety to avoid exposure to any harm. Since implementation, it was observed that the use of this system has led to many positive results, as it has reduced the number of incidents of school transport by 63%; reduced the number of student users of private cars to get to school by 9%; increased the number of students that use the school buses by 5.5%.

Here presented a system which is called, Smart School Bus Architecture. The student swipes the card at the RFID reader while boarding the bus, when the RFID reader transmits the student identification to mobile DVR, which will transmit student identification to the CMS server using 2G/3G/WIFI network. The CMS server will send SMS to assigned parents mobile, then the parents will receive the message and then the bus will depart. During the bus is moving, the mobile DVR will record (video/audio) the various school bus spots that will be shown in the CMS server through 2G/3G/WIFI network as well as there is a GPS used for tracking and monitoring the smart bus location at the central monitoring site. School management permits and allows parents to access the monitoring system that enables them to monitor their children via the internet using browser/CMS client. In case of incidents, urgent communication or alarm trigger on the CMS server by the driver and then the CMS administrator will communicate directly with the driver using a mobile DVR system through 2G/3G network.

Zonar has designed the Zpass specifically for

school buses for monitoring and tracking the students in a safe manner. Zpass provides accurate and immediate answers. This system uses RFID with a small card carried by the student containing passive RFID technology that records each student's entry or exit automatically when the student passes from the scanner device that located in the school bus. Through that, parents can receive information from the student through the mobile phone or computer browser with Zpass+, which gives parents a new level of comfort and confidence, using the information that is collected from Zpass, simple notifications send directly whenever the child gets on or gets off from the school bus through SMS to the parent's mobile phone.

### Proposed System Framework

The system block diagram of the proposed system is shown in the following figure (Figure 1). The major steps involved in the system development are explained there under.

#### ID20LA Innovation RFID Reader

The function of the RFID reader is integrated with RFID tags. It contains the reader module, which works as both the transmitter and receiver of radio frequency signals. The transmitter consists of an

oscillator to create a carrier frequency, a modulator that impacts on data commands, and amplifier to enhance the signal enough to awaken the signal. On the other side, the receiver has a demodulator to extract the restored data and it contains an amplifier to strengthen the processed signal. The microcontroller forms a control unit that stores data and then sends it to the network. They have three series set ID3, ID12, and ID20 and these all are LA series. The experiment uses ID20LA innovation as it is the biggest kind of ID. It can be read any RFID card within range, and any microcontroller can easily read it.

#### GSM Modem

SIM900 GSM modem is used in this implementation as it allows sending SMS to the management of the school via internet. This modem is a type of modem that accepts SIM card, and operates through a subscription to a mobile operator. It works like a mobile phone for sending and receiving SMS or MMS through radio waves. It is slim and compact, the main advantage of choosing this particular modem is, it has low power consumption. This modem has a GPRS feature that allows transmitting the data via the internet in different methods such as SMS, GPRS, or CSD.

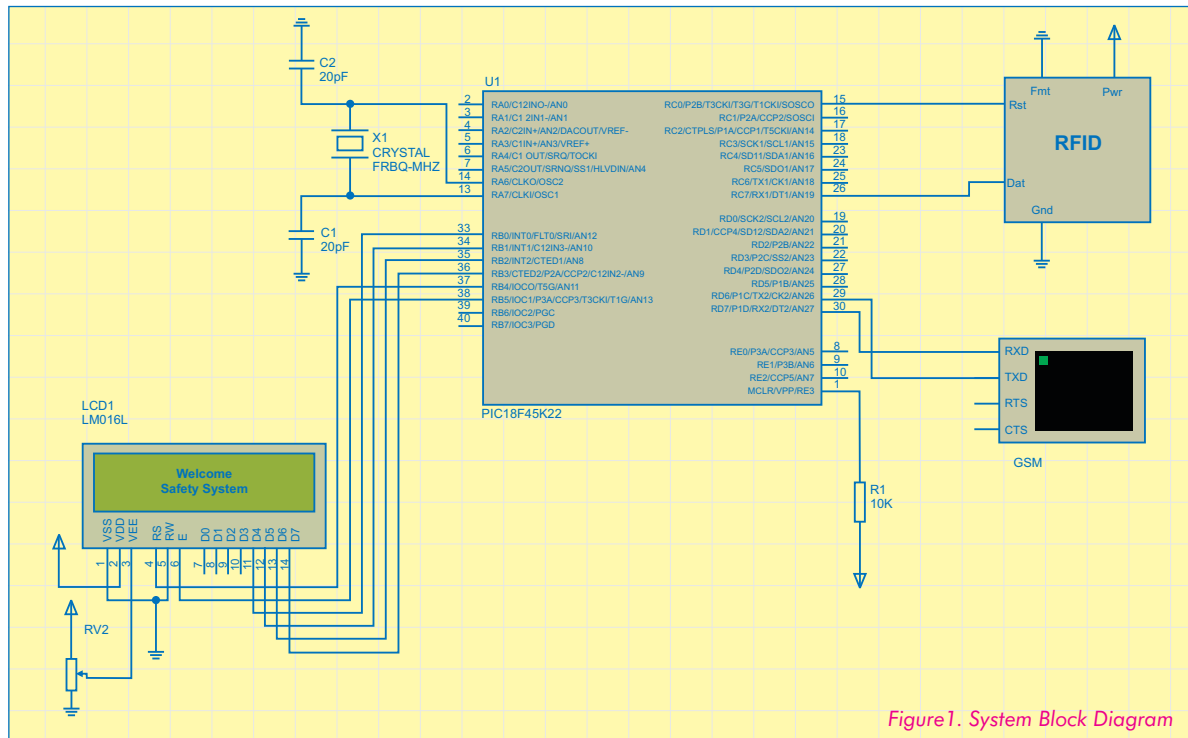

Figure 1. System Block Diagram

**PIC18F45K22 Microcontroller**

The famous families of microcontrollers are AVR, and PIC. PIC18F45K22 is one type of the PIC that has been chosen for this experiment. PIC18F45K22 introduces and offers design enhancements that make it the best choice for most applications. Low power, high performance, high computational performance, high endurance, and flash program memory are some features of this PIC.

**16x2 LCD**

The experiment used 16x2 LCD as it is economical, and easily programmable. 16x2 LCD means that it is able to display 16 characters per line on two lines. This LCD has two resistors. Liquid Crystal Display (LCD) is an optical device consisting crystals arranged on a thin surface. LCD has certain features such as; its size is much less than the regular screen, light and easy to transport, does not need high voltage of electricity like in the regular screens, comfortable for the eyes compared to regular screen, their shape is much better than normal screen, and its quality is higher than normal screens in terms of colors.

**RFID Tag (Card)**

RFID tag stores unique digital identity codes that can be scanned from a distance and as well as to capture the signals and send them to the reader. RFID comes in different forms such as a label card, which can have a barcode printed on it. RFID tags are used in many industries, where it can be used to track by suspending it in the automobile during production or it can be injected into animals that allow identifying the animals. In addition, it can be attached to clothing or even implanted in people to determine the identity of the person. RFID tags can be active, passive, or semi-passive. The experiment has used a 40 bit unique ID, it cannot be reprogrammed, blank, flexible, and white in colour.

**Crystal Oscillator**

It is an electronic circuit which produces vibrations with a very specific frequency to provide a stable clock signal for the integrated circuit. MHZ quartz crystal has been used in the experiment for synchronization.

**AT Commands**

AT Commands are a specific command language

Command & Code	Description
AT [Tx_String("AT");:]	Check modem connection Response OK
AT+CLIP [Tx_String("AT+CLIP=1");:]	Calling line identification presentation
AT+CMGF [Tx_String("AT+CMGF=1");:]	Select SMS Message Format AT+CMGF={<mode>} Parameters <mode> 0 PDU mode 1 text mode
AT+CPMS [Tx_String("AT+CPMS={\"SM\"}");:]	Preferred SMS Message Storage SM = SIM card Memory
AT+CMGDA [Tx_String("AT+CMGDA={\"DEL ALL\"}");:]	DELETE ALL SMS Parameters 1) if text mode: "DEL READ" delete all read messages "DEL SENT" delete all sent SMS "DEL ALL" delete all SMS 2) if PDU mode: 1 delete all read messages 3 delete all sent SMS 6 delete all SMS
AT+CMGR [Tx_String("AT+CMGR=");:]	Read SMS message
AT+CMGS [Tx_String("AT+CMGS=");:]	Send SMS message

Table 1. AT Commands

used to control modems to do their specified functions. The command set consists of a series of short text strings which are combined together to produce complete commands for operations such as dialing, hanging up, sending messages and changing the parameters of the connection. As for the proposed project, a set of commands are required to establish a connection between the mobile operator and the GSM modem. All used commands are explained in the table 1.

**Mikrobasic Software**

Mikrobasic is a rich development tool for PIC microcontrollers. It is designed to provide the easiest solution for the programmer to develop applications for embedded system without compromising performance and control.

Mikrobasic has various features such as it allows programmers to develop and deploy complex applications quickly, getting detailed report and graphs such as RAM and ROM map, code statistics, and more, providing plenty of examples to expand, develop, and use as building bricks in projects, monitoring the program structure, variables, and function in the Code Explorer, and inspecting the program flow and debug executable logic with integrated software simulator.

A. System Flow Chart –The flow chart explains the operation of the system. The system starts once the students scan their card into the RFID reader. The

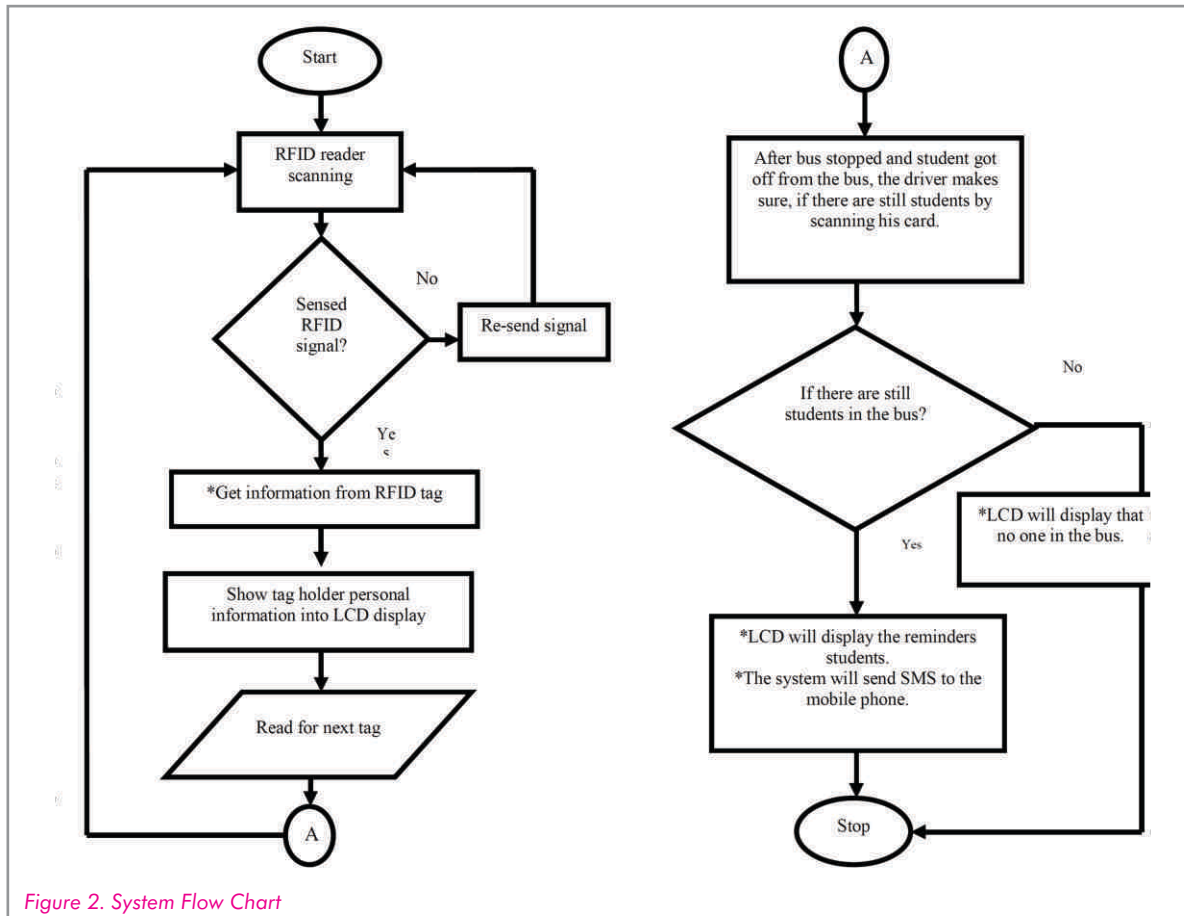

RFID reader will sense the medium, if it captured any data from the RFID tag (card), the system will show the data into LCD display. If it is not, the RFID reader will re-sense the medium to read the next tag. After the bus stop the driver makes sure if there are still students inside the bus by scanning his card. If there are still students on the bus, the LCD will display the reminders students and the GSM will send an SMS message to the school management. If there are not, the LCD will show, there is nobody on the bus.

This flow chart explains the operation of the system. The system starts once the students scan their card into the RFID reader. The RFID reader will sense the medium, if it captured any data from the RFID tag (card), the system will show the data into LCD display. If it is not, the RFID reader will re-sense the medium to read the next tag. After the bus stopped, the driver makes sure if there are still students inside the bus by scanning his card. If there are still students on the bus, the LCD will display the reminders students and the GSM will send an SMS message to the school management. If there are

not, the LCD will show, there is nobody on the bus.

B. System Working Principle– The working principle of the bus safety system is that since each student carries a card that contains a unique number with his/her name, so once the students start entering the bus, the RFID reader will capture their names and display them into a screen placed in front of the driver. Then after the bus stopped and students got off from the bus, the driver will scan his card to make sure, if there are still students inside the bus. If there are, the system will display their names into the screen and then it will send SMS to the school management to take the right decision.

The system will also send the message to the management to inform them the safe departure and arrival of the bus to the destination.

## Implementation

### A. Software Implementation–

System circuit has designed by using the ISIS 7 Professional (Proteus) program with all required components and the simulation has carried out.

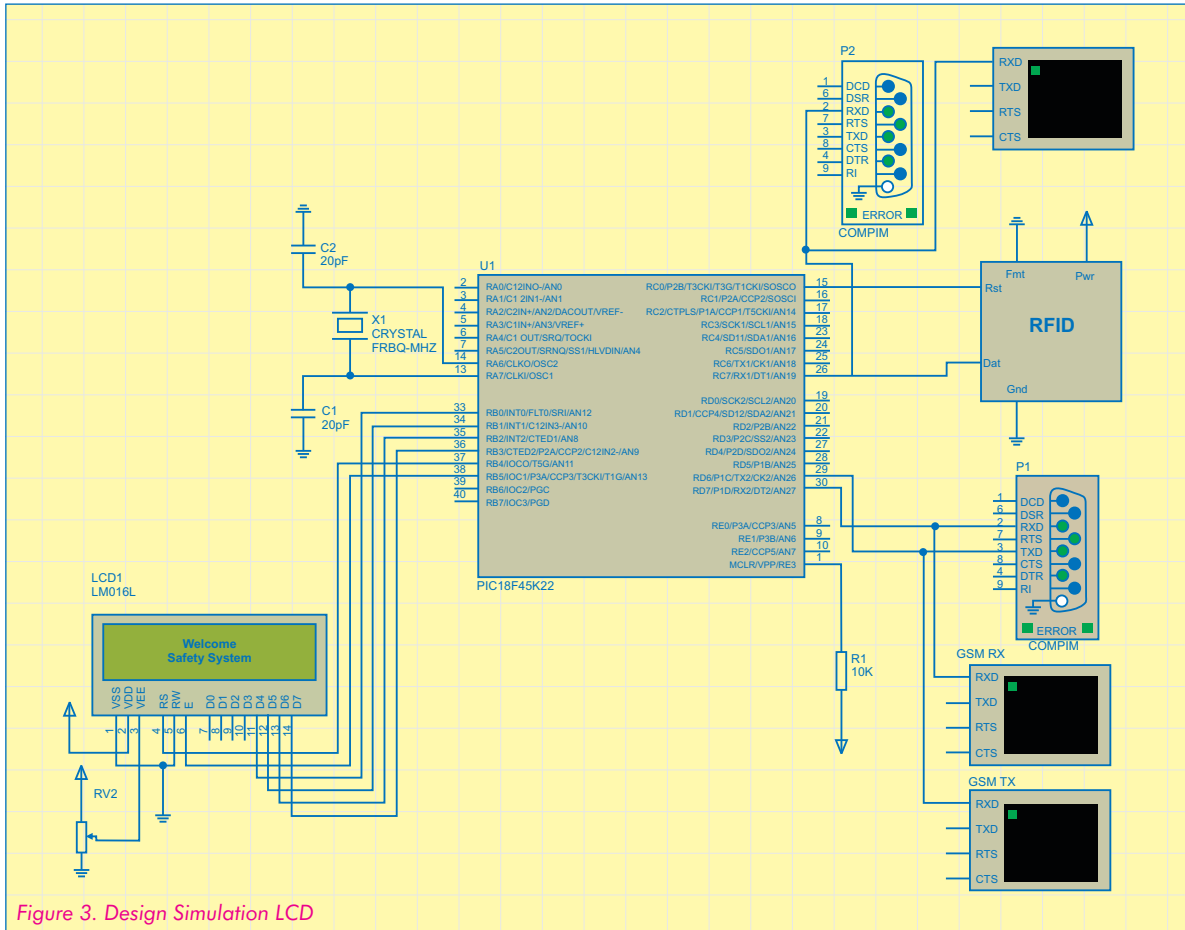

Figure 3. Design Simulation LCD

Since the GSM modem and the RFID reader could not be simulated by the Proteus, an actual GSM modem and RFID reader have physically connected to the computer through a serial port to facilitate the communication between the Proteus program and the external devices to implement the simulation. While the LCD has stimulated by the program successfully to display the system operation as showed in the Figure 3.

After the simulation has made, the PCB layout of the system has designed and constructed into the breadboard.

**B. Hardware Implementation–**

System circuit has designed by using the ISIS 7

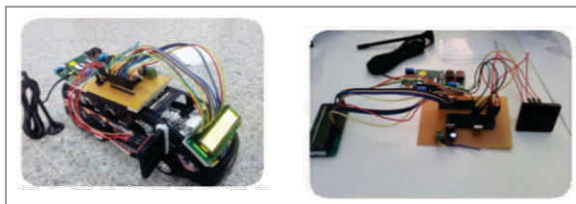

Figure 4. PCB - System Prototype

Professional (Proteus) program with all required components and the simulation has carried out. Since the GSM modem and the RFID reader could not be simulated by the Proteus, an actual GSM modem and RFID reader have physically connected to the computer through a serial port to facilitate the communication between the Proteus program and the external devices to implement the



Figure 5. The Entering Students Moment

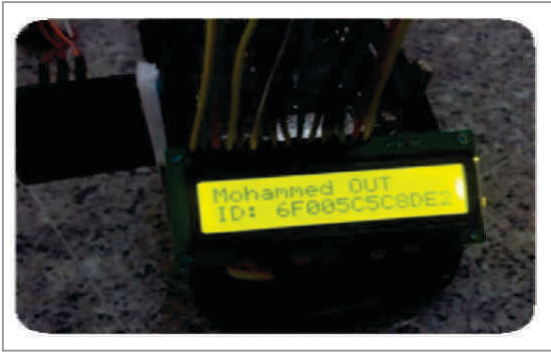
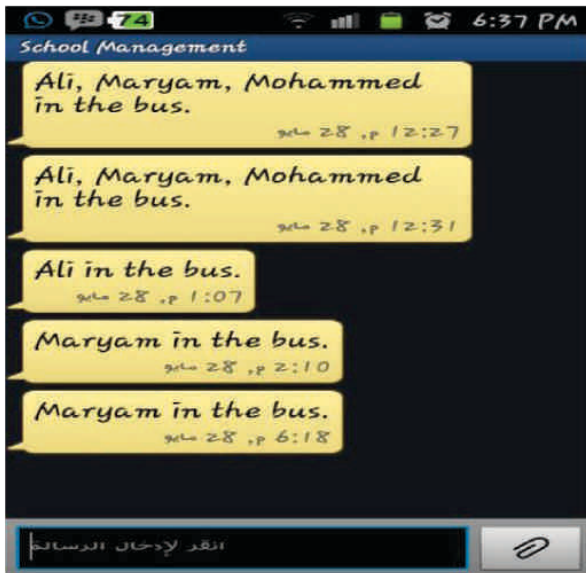

Figure 6. The Exiting Students moment

simulation. While the LCD has simulated by the program successfully to display the system operation as showed in the Figure 4. After the simulation has made, the PCB layout of



the system has designed and constructed into the breadboard.

After carrying out the system simulation, designing the PCB using Proteus program, printing it into the PCB, and testing was carried out. All components have collected and connected to the PCB as shown in Figure 4. Then, the implementation of the system was tested and the prototype has designed as shown in the figure 5.

Once the card of students scanned via the RFID reader, the data of each student (Name, ID) displays in the LCD.

For example, as shown in the Figure 6, once the students entered into the school bus, the LCD displayed that the students have entered to the bus

with their information. This helps the driver to know the existing students on the bus.

After that, the driver will make sure if there are still students inside the bus by scanning his card via RFID reader. If there are still students, the LCD displays their names and then the system will send an SMS message to the School management as shown in the Figure7 to take the right decision.

## Results

The system implementation was tested and it found that the system has worked as expected. Firstly the system was simulated in the Proteus software. Then, the system was programmed by Mikrobasic software and tested in Easy PIC7 development board. After the simulation of the system was tested, a toy bus was used to test the system. The RFID reader is fixed on the bus door. The RFID reader has tested by entering the tags (cards) in the bus through it.

While the GSM has tested by connecting the GSM modem to a PC directly through the USB cable. Then the GSM has tested by using AT command tester program. For example, if AT is written and the reply was 'ok', this was meant that the communication with the GSM modem worked fine. Some other basic AT commands have checked and tested to make sure that the GSM modem is working successfully. In addition, the LCD was fixed in front of the bus and it has tested to perform the operation of the system.

## Conclusion

The integration of RFID and GSM technologies for safety and security purpose is very important nowadays due to increase in accidents of children gets missed out at the bus which may lead to death due to suffocation. In this project, bus safety system for school children has been developed. Using this system, concerned authorities, bus driver can be alerted as it's visible from the RFID card. At the same time, in case if there was a student on the bus, the system will send an SMS message to the management of the school to take the right decision. The project shows that that RFID technology based tracker system is still acts as one of the best solution to enhance the safety in the school buses, which will reduce the accidents of forgetting the students inside the bus.

